

DECK DETAIL

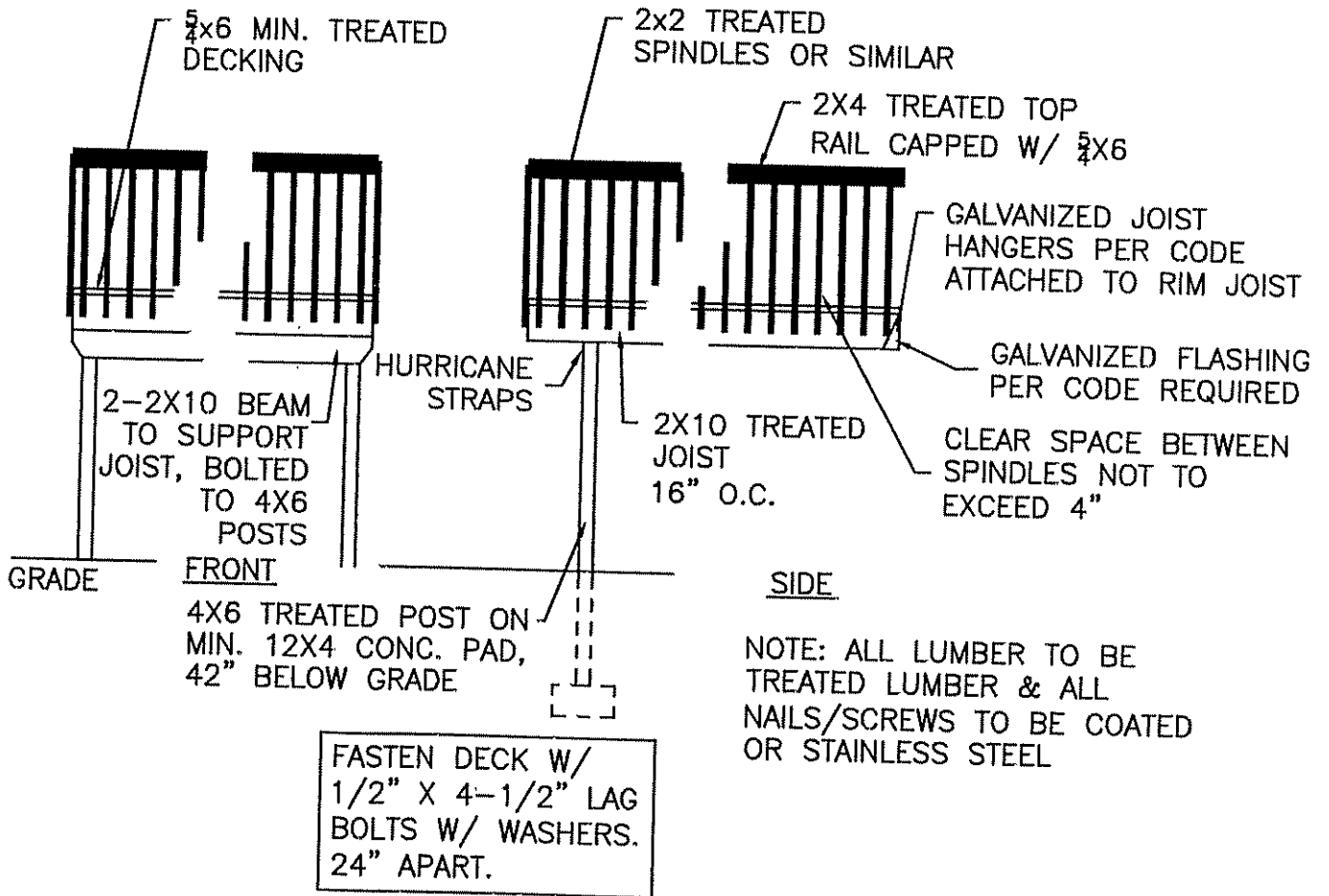

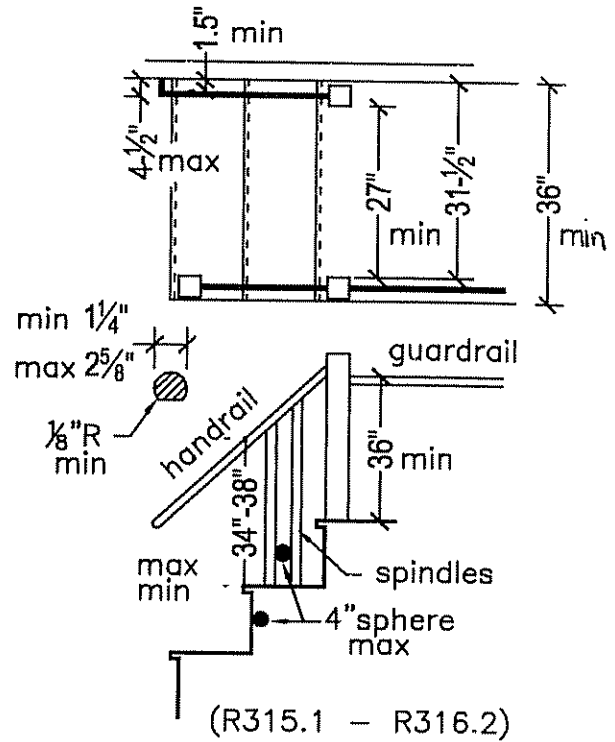
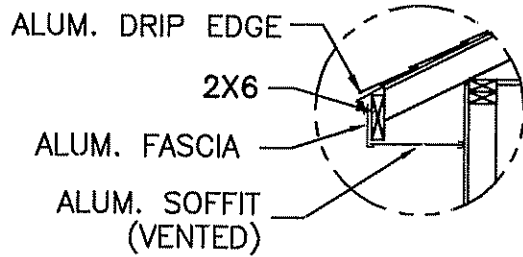
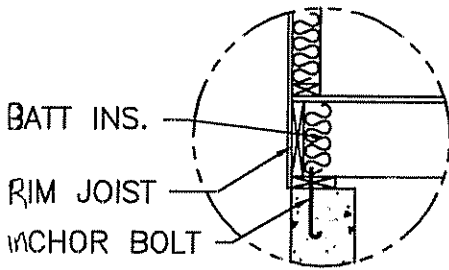

Handrails and Guardrails

25 YEAR MIN. ASPHALT SHINGLES, ON 15# FELT, ON 7/16 X 4 X 8 OSB BOARD, ON PRE-ENGINEERED ROOF TRUSS 24" O.C.

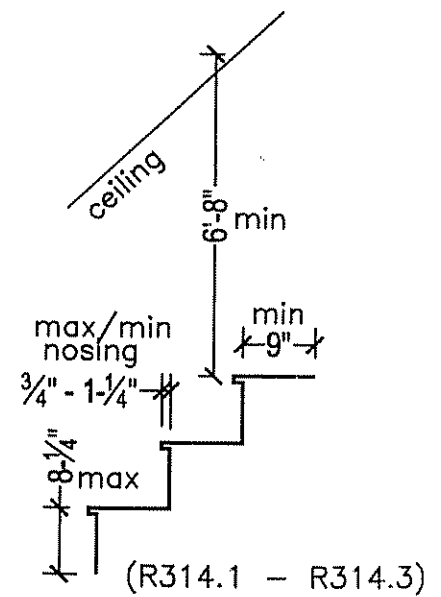
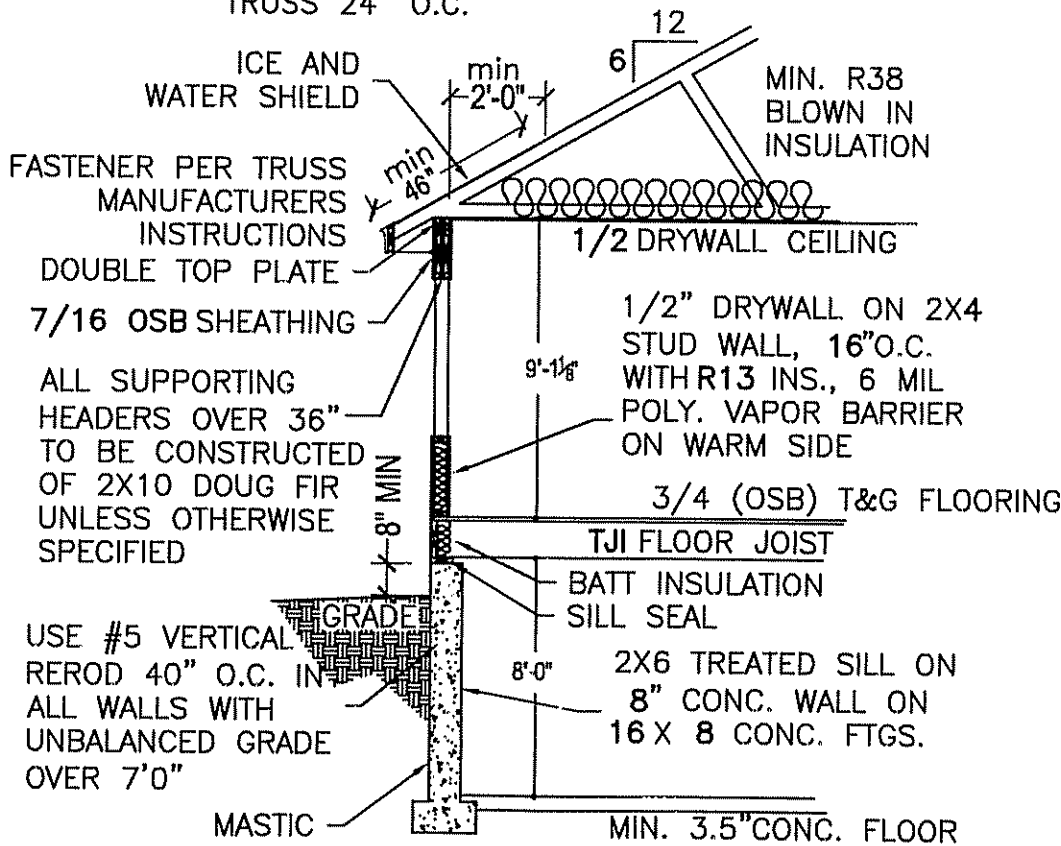

Stair Requirements

6 MIL POLY. VAPOR BARRIER UNDER GARAGE AND BASEMENT FLOOR

TYVEK, TARPAPER OR APPROVED SIMILAR HOUSE WRAP MUST BE APPLIED TO EXTERIOR. SEE INSTRUCTIONS AT WWW.SNAD.COM